



KS



HOLZSTAUB
RICHTWERT
EINGEHALTEN NACH
TRGS 102

Foto della macchina conforme alle norme CE •
Abgebildetes Modell in EG-Ausführung •
Picture of the machine in CE version •
Photo de la machine conforme aux normes CE •
Foto de la máquina conforme normas CE •

**LEVIGATRICE PER BORDI
KANTENSCHLEIFMASCHINE
EDGE SANDING MACHINE
PONCEUSE DE CHANTS
LIJADORA DE CONTORNOS**

• Le misure ed i pesi sono approssimativi. La Ditta si riserva di apportare migliorie e modifiche senza alcun preavviso. • Abmessungen und Gewichte können ohne vorherige Ankündigung geändert werden. • Weight and dimensions of machines, as well as performances, can be changed or modified at any time without notice.
 • Les dimensions et les poids sont approximatifs. La Maison peut apporter des améliorations et des modifications sans aucun préavis. • Las Medidas y pesos sono aproximados. La empresa se reserva el derecho de modificarlas sin previo aviso.



DATI TECNICI	KS 420
Motore trifase HP/KW	2 (1,5)
Velocità nastro m/sec	15
Lunghezza utile di lavoro mm	850
Larghezza nastro mm	150
Sviluppo nastro mm	2250
Dimensioni piano mm	650x220
Dimensioni piano posteriore mm	350x250
Inclinazione nastro	0÷90°
Peso netto Kg	100



TECHNISCHE DATEN	KS 420
E - Motor 380 V PS/KW	2 (1,5)
Bandgeschwindigkeit m/Sek	15
Arbeitslänge mm	850
Bandbreite mm	150
Bandlänge mm	2250
Tischgröße mm	650x220
Zusatztischgröße mm	350x250
Schleiteinheit Schwenkbar	0÷90°
Gewicht Kg	100



TECHNICAL DATA	KS 420
Treephase motor HP/KW	2 (1,5)
Belt speed m/sec	15
Working length mm	850
Width of the belt mm	150
Length of the belt mm	2250
Table dimensions mm	650x220
Additional table dim. mm	350x250
Blade tilting	0÷90°
Net weight Kg	100



DONNÉES TECHNIQUES	KS 420
Moteur triphase CV/KW	2 (1,5)
Vitesse de la bande m/sec	15
Longueur de travail mm	850
Largeur de la bande mm	150
Longueur de la bande mm	2250
Dimensions table mm	650x220
Dimensions table adjointe mm	350x250
Inclinaison du ruban	0÷90°
Poids net Kg	100



DATOS TECNICOS	KS 420
Motor trifásico HP/KW	2 (1,5)
Velocidad de la bande m/seg	15
Longitud. mesa de trabajo mm	850
Anchura banda lijado mm	150
Longitud. banda lijado mm	2250
Medidas mesa mm	650x220
Medidas mesa adjunta mm	350x250
Inclinación de la banda	0÷90°
Peso neto Kg	100

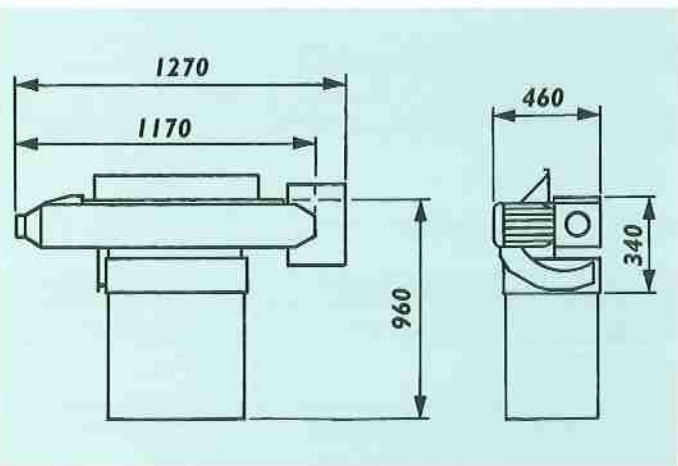

• A RICHIESTA • ZUBEHÖR • OPTIONALS •
 • OPTIONS • PRINCIPALES OPCIONALES •

- Piano per levigare pezzi sagomati al rullo con cappa di aspirazione
- Tisch zum Schleifen runder Innenkanten an der Rolle mit Absaughaube
- Table for round sanding at the roller with suction hood
- Table pour le ponçage au rouleau des pièces courbes avec capot d'aspiration
- Mesa para lijar a rodillo con capa de aspiración



- Impianto elettrico a norme CE
- Elektrische Anlage nach CE - Vorschrift
- Electric installation according to CE
- Installation électrique selon normes CE
- Instalación eléctrica según reglas CE



- Squadretto per levigature angolate
- Winkelschleifanschlag
- Little fence for angled sanding working
- Equerre pour polissages anguleuses
- Escuadra para hacer lijaduras angulares



- Piedistallo
- Untergestell
- Base
- Piédestal
- Pedestal

